

VC-210

OPERATION MANUAL

Contents

- I Overview
- II Main Technical Specification
- III Main Function
- IV Working Principle
- V Operation Instruction
- VI Installation
- VII Maintenance and Safeguards
- VIII Troubleshooting
- IX List of Main Elements
- X Guarantee

I Overview

VC-210 weight indicator is an intellectualized instrument with microprocessor, featuring stable and accurate weighing, AC power supply, LCD display, low power consumption, compact structure, light weight and easy operation. Thus it is ideal for electronic table scale, electronic ground scale, and various weight measuring devices.

II Main Technical Specification

1. Accuracy: III
2. A/D conversion speed: 40 times/sec.
3. Inner resolution ratio: 400 thousand
4. External resolution ratio: 1/1000-1/15000
5. Non-linear error: <0.016% F.S
6. Range of signal input of the transducer: 0-20mV
7. Exciting power of transducer: +DC5V; four 350 Ω or 1000 Ω transducers allowed
8. Power supply: (1) six DC1.5V dry batteries (2) DC6V1.2Ah chargeable battery (if need, please specify it in the order) (3) AC/DC 12V 300mA adapter power;
9. Display: big 6-digit LCD (with background lighting) display with figure height up to 22mm
10. Symbol indication: battery; stable; gross weight; net weight; tare deduction; zero set; carat; ounce; pound; kilogram;
11. Power consumption: 0.1VA
12. Operating temperature: 0-40°C
13. Operating humidity: \leq 85%
14. Outer dimensions: 210mm \times 140mm \times 88mm
15. Weight: about 0.8kg

III Main Function

1. Automatic keyboard calibration; automatic regulation of weighing range by software;
2. Error indicator;
3. Automatic shut-down in preset time (20-30min);
4. Indication and automatic shut-down in undervoltage;
5. Filter to avoid vibration and shake;
6. Free conversion of kg/lb on the panel
7. Print out port: weight printing and printing of accumulative weight available
Equipped port: RS-232; RS-485; 20mA current ring (if need, please specify it in the order);
8. Automatic program reset: high anti-jamming performance; no loss of key parameter
9. Free set of decimal point with maximum weighing capacity; multi resolution ratio available;
10. Auto-tracing of zero digit; abnormal zero digit alarm; overloading alarm;
11. Signal indicators:
 - (1) Battery: it lights when voltage is too low
 - (2) Stable: it lights in stable weighing
 - (3) Gross weight: it lights when tare is zero
 - (4) Net weight: it lights when tare is displayed
 - (5) Tare deduction: it lights when tare deduction is required
 - (6) Zero digit: it lights when weight value is zero
 - (7) Kilogram: it lights when 'kg' is chosen
 - (8) Pound: it lights when 'pound' is chosen
 - (9) Ounce: it lights when 'oz' is chosen
 - (10)Carat: it lights when 'ct' is chosen

(11) Minus sign: it lights when weight value is negative

IV Working Principle

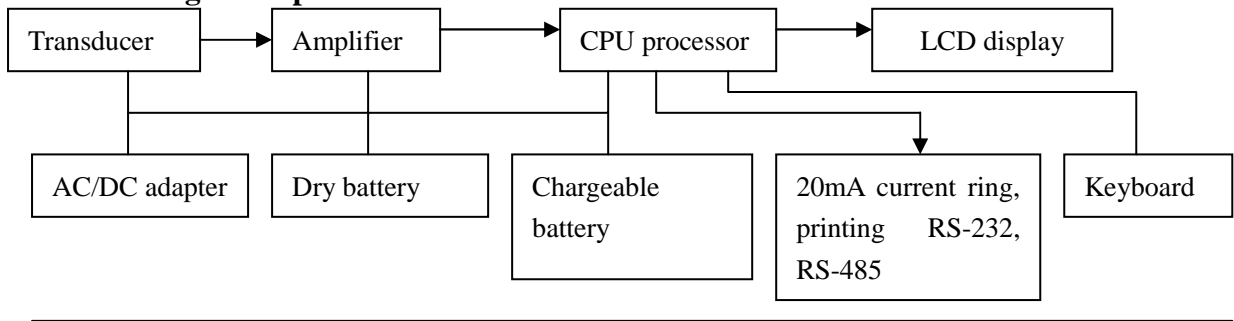

Figure 1: Principle Diagram

VC-210 weight indicator comes with LCD display that applies extended strain-weighing transducer with high precious resistance and special power supply (+5V). When deformation occurs due to pressure imposed on the transducer, the output voltage signals are directly proportional to the force imposed.

Signals output from transducer are amplified by calculating amplifier with high gain, low drift and high impedance output. As program of zero adjustment and auto zero tracing through software of monolithic microprocessor is applied, drift generated by transducer and DC amplifier is overcome, thus automatic zero adjustment is achieved and the equipment enjoys long-term stability.

V Operation Instruction

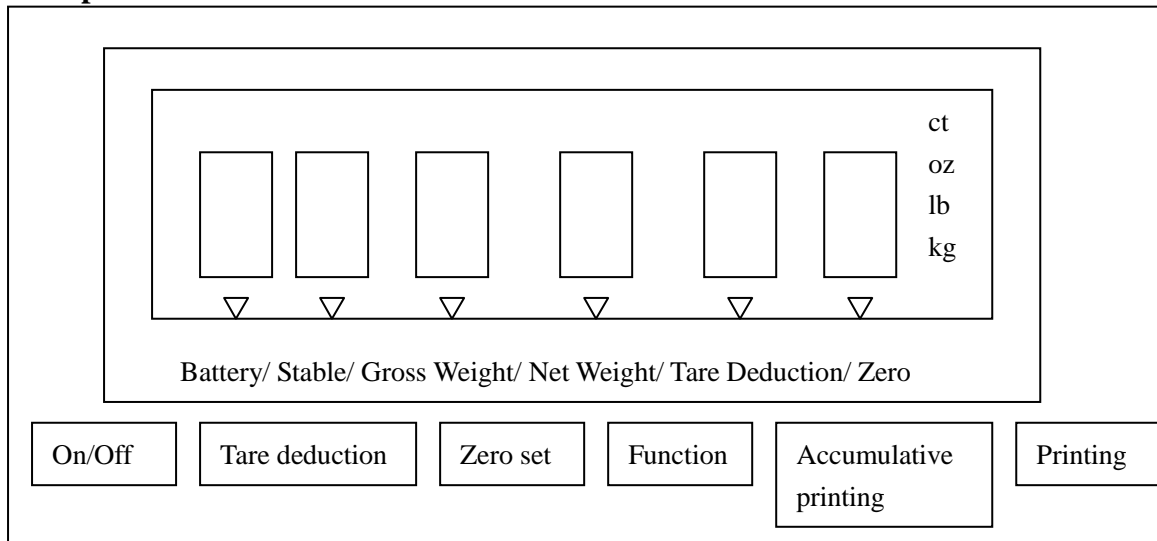

Figure 2 Panel of the weighing equipment of SME series

1. Usage of buttons

- (1) 'ON/OFF': for on/off of power; press this key, the equipment enters into weighing status after 0-9 self-checking; when power on, press this button for 1.5 seconds, the panel displays quantity of battery electric charge in percentage: 'bpt 99' and then power is cut;
- (2) 'TARE': press this button to deduct current tare and displays net weight;
- (3) 'ZERO': for zero setting of the scale; range of zero set is $\pm 2\%$ of total;
- (4) 'MODE': for automatic conversion of diversified functions and weight display;
On/off of background lighting: press 'Mode' button for 1.5 seconds to on or off background lighting;

- (5) 'PRINT': press this button once to print current weight; accumulative times 'n××' and accumulative weight 'YYYYY' will be displayed for 1.5 seconds respectively; During above operation, press 'zero reset' button to eliminate accumulative times and accumulative weight.
- (6) 'ACC PRINT': for accumulative printing of current weight; accumulative times 'n××' and accumulative weight 'YYYYY' will be displayed for 1.5 seconds respectively; During above operation, press 'ZERO' button to eliminate accumulative times and accumulative weight.

Print format:

Press 'PRINT' button once to print current weight; number 1-10 on printing sheet refers to serial number; press 'ACC PRINT' for accumulative printing of current weight (unit of the time shall prevail.)

NO	WEIGHT
1	2.000 kg
2	6.000 kg
3	9.920 kg
4	10.000 kg
5	12.000 kg
6	20.000 kg
7	30.000 kg
8	40.000 kg
9	50.000 kg
10	60.000 kg
Add 10 239.920 kg	

2. Preset of automatic shut-down and buzzer

Do not conduct the following operation until the circuit breaker is set at 'off' position:

Depress 'TARE' button for 1.5 seconds, the equipment will display 'OFF××', ×× denotes time of shut-down respectively for 3, 10, 15, 30 and 0 by depressing 'PRINT' in a circular order to select the specific figure. Figures 3, 10, 15 or 30 respectively indicates that if no change of weighing value or no change on the keyboard after 3, 10, 15 or 30 minutes, the equipment will be shut-down automatically; but 0 denotes automatic shut-down function is not available. Press 'MODE' button to input the value.

At this moment, 'bp on' or 'bp off' is displayed on the equipment. To choose 'On' or 'Off' for indication of buzzing or non-buzzing, just depress 'PRINT' button. To choose non-buzzing mode help to save more power consumption. After the choice, depress 'MODE' button to resume weighing mode.

VI Installation

1. Cording diagram of signal wire of the transducer

Before the first use, for better performance of the electronic scale, welds the output wire of transducer with 5-pin round plug (see figure 2); then insert the plug into 5-pin socket and fasten the screw; make sure the plug should be fixed well in the socket.

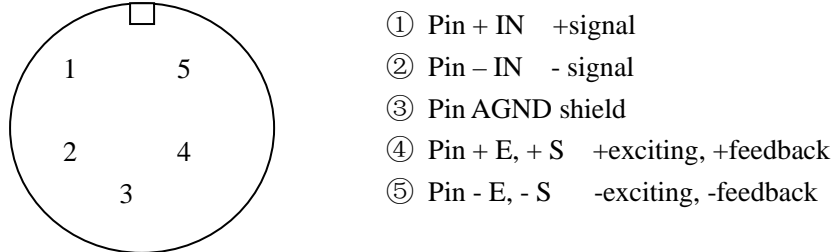

Figure 2: Cording diagram of 5-pin round plug of the transducer

Note: for 6-pin transducer, please remember to connect + E, + S and - E, - S in short circuit.

2. Cording diagram of RS-232 (if need, please specify it in the order)

RS-232 serial interface adopts D-SUB-9 (needle) plug as figure 3 shows:

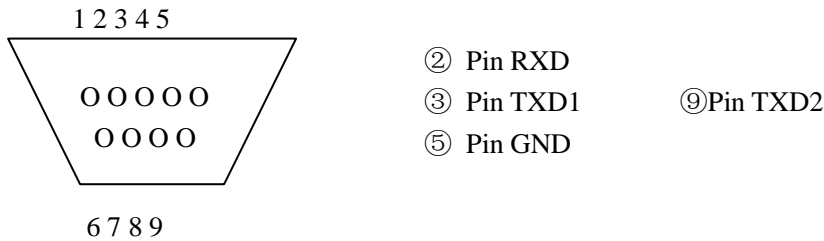

Figure 3: Cording diagram of RS-232 plug

3. Cording diagram of 15-pin plug for 20mA current ring and RS-485 output (please specify in ordering)

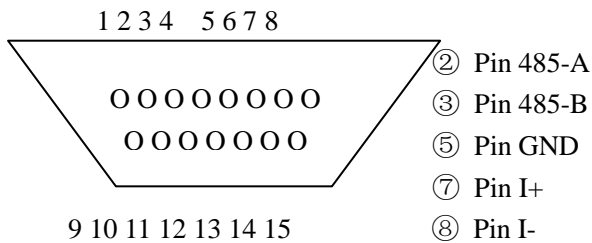
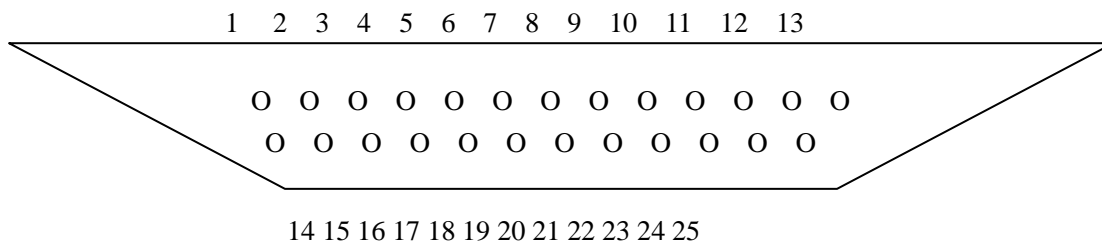

Figure 4: Cording diagram of 20mA current ring and RS-485

3. Cording diagram of 25-pin plug with printing serial output



(1) Pin: STRB (2)-(9) Pin: D0-D7 (11) Pin: BUSY (10), (12)-(18) Pin: empty
 (19)-(25) Pin: GND

4. Fit of dry battery

Fit six #5 dry batteries into the battery box as signs of positive pole + and negative pole – guides. After a period of use, the equipment may display a sign of under-voltage, indicating that it is time to replace battery.

5. Fit of chargeable battery (please specify in the order if required)

The chargeable battery is 6V1.2Ah. The red line end is positive pole, while the black line end is negative pole. Connect the wiring terminals and fasten the screw to fix the battery well.

6. Fit of AC/DC adapter

Insert the DC plug of AC/DC adapter (specification: 12V300mA) into a 'DC' socket, while insert the other end into relevant AC socket and connect 220V power supply. In case there is no AC supply (or fails to insert the adapter into 200V power supply) and dry battery is used instead, do remember to pull out DC plug of the adapter, otherwise the equipment will fail to work.

In case voltage of chargeable battery is too low, it may be recharged through adapter supply (insert the adapter into 220V power supply to achieve automatic charging);

VII Maintenance and Safeguards

1. To ensure long working life, do remember not to use the equipment in place where there is direct sunshine. Place it on even and flat location.
2. Do not use the equipment in place where there exists dust or serious vibration.
3. It is strictly forbidden to exceed the maximum weighing capacity (including the tare) in weighing.
4. Pull out the power plug if it is idle.
5. When under-voltage sign of battery appears after a period of use, it indicates that it is time to replace or recharge the battery; otherwise it may affect measuring accuracy;
6. It is strictly prohibited to clean the outer case with strong solvent such as benzene and nitryl oil.
7. Never let water go into the equipment, as it may damage electronic elements and get an electric shock.
8. For any troubles, pull out the power plug first, and then take it to our factory for maintenance. Do remember not to repair it by yourself, as it may cause worse trouble.
9. It is strictly forbidden to open any weighing scales with lead sealing in operation.

VIII Troubleshooting

Troubles	Causes	Solutions
No display when on/off button is depressed.	Adapter not connected to 220V power supply yet, or no batteries in.	Connect the adapter to a 220V power supply or fit in dry batteries or chargeable batteries.
No reaction when on/off button is depressed.	Poor contact of soft touch switch	Replace a new soft touch switch.
No reaction when on/off button and other button are depressed.	Poor contact of soft touch switch	Replace a new soft touch switch.
Incomplete words are shown up when self-check of equipment has been done.	Poor contact or false welding or damage from impact on pins of LCD chips	Replace a new LCD display.
Inaccurate weight value is displayed on the equipment.	Badly-welded cord of transducer or fatigue of transducer due to overload operation for a long time.	Check the cord and the welded plug; calibrate it as shown in the manual.
Readings are not stable when no load is on the scale platform.	Alien objects beneath the platform or the 4 feet of scale are not even on the ground, or serious vibration, or transducer cords spring up and touch the platform;	Open the platform, check and clean it; make sure not to clean it with water.
No reaction from the buzzer when any button is depressed.	The preset buzzer fails to sound or it is damaged.	Preset the buzzer or replace a new one.
Calibration fails to be done.	The circuit breaker is not set at 'On' position.	Set the breaker at 'On' position.
Display of weight value differs from the weights after calibration.	The weights loaded do not agree with the maximum weighing range.	Place on weights within the maximum weighing range as indicated on the nameplate.
The word ERROR appears during calibration.	Incorrect welding of transducer cords; or mistakes in analog calibration.	Check the cords; weld it again and conduct calibration as indicated on the nameplate
The equipment fails to resume to zero position after calibration	Heavy objects are loaded on the platform during calibration.	Clear off the heavy objects and calibrate again.
Readings are not accurate after work for a period of time.	Under-voltage of batteries in operation; the sign of battery is displayed.	Replace new batteries or recharge it.

IX List of Main Elements

No.	Name	Specifications
119L001	Assembly of circuit board	SME (PCB) assembly
119L002	Non-dry glue panel	SME weighing equipment
119L003	LCD display	SME (LCD)
119L004	Soft touch switch	12×12×13
119L005	Buzzer	5V φ12
119L006	AC adapter	12V300mA
119L007	Chargeable battery	6V1.2Ah
119L008	Dry battery	1.5V5#×6
119L009	Round 5-pin signal plug (socket)	Round big 5-pin
119L010	Plug (socket) with single-row signal	2×2.54
119L011	Plug (socket) with single-row signal	3×2.54
119L012	Plug (socket) with single-row signal	5×2.54

X Guarantee

We guarantee one-year of free maintenance since the date of purchase for any non-manmade faults in normal working conditions. For maintenance, please send the equipment with the guarantee card to our after-sales division.